

Pull-Lock Stop-End (non-tensioning) Fittings Installation Instructions



Make sure the holes are drilled properly in the posts where you will be installing your fittings.

If you are installing the fittings in a metal railing, see *Metal Railings/Hardware Mounting Holes/Boring Guide* for boring instructions.

If you are using wood end posts, see "Wood Railings-Mounting Alternatives" section in this guide (pages 10-12) for hole sizes.

For wood, first drill a pilot hole through the post that is 1/16" larger than the diameter of the cable you are using. (It is best to drill the pilot hole all the way through from the inside out.) Then drill a 29/64" hole from the back side of the post at least 1-3/4" deep (deeper if you are counterboring for the over-sized washer).

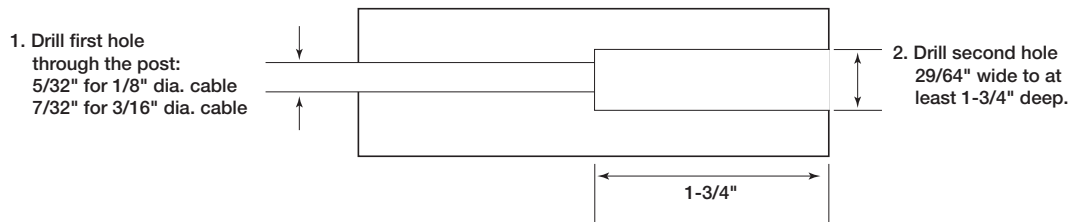

- Following the instructions elsewhere in this guide for the tensioning device you will be installing on one end of the cable run, install the tensioning device to your end post on one end of the cable run first (Post A below).



- Run the cable through the intermediate posts (if any) and through Post B where you will be installing the Pull-Lock fittings.

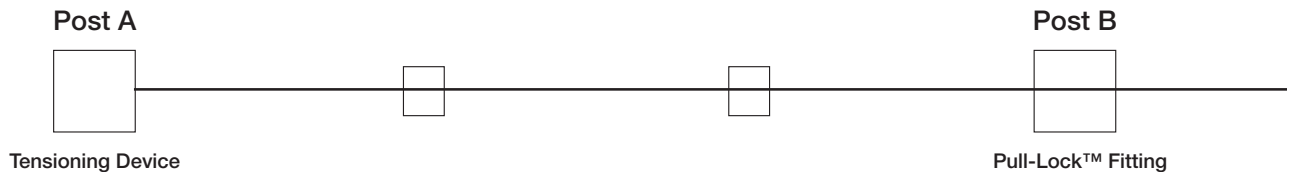

- Cut the cable with a cable cutter, leaving enough cable extending out from the back side of the post to be able to grasp the cable firmly with your hand (6" or more).

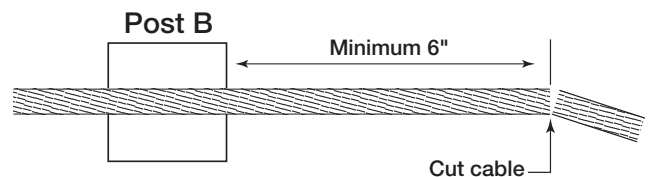

Pull-Lock Stop-End Fittings (continued)

- Slip the washer over the body of the Pull-Lock fitting (7/16SAE washer for wood posts, black Delrin® washer for metal posts).

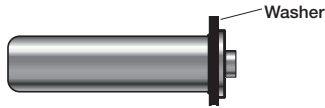

- Push the cable into the hole in the front of the Pull-Lock fitting and pull the cable through the fitting. Twist the cable clockwise as you push it into the fitting. Then slide the fitting along the cable and up to the back side of the post. (If applicable, you will receive a PL-Key with your order. This may aid in your cable installation. Please see instructions for use of the PL-Key at the end of this section).

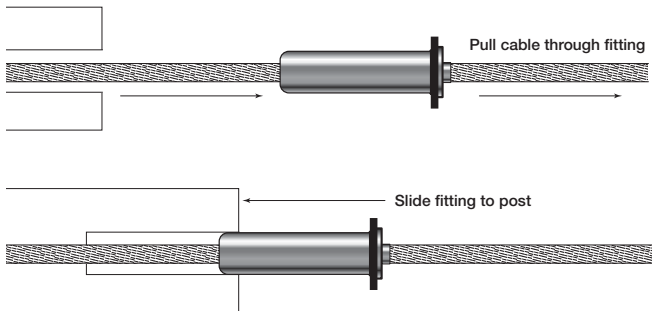

Note: If you have trouble inserting the cable into the fitting, it may be because the locking wedges have become stuck. This is not a defect! Here's what you can do to "free the wedges" —
 For Pull-Lock or Push-Lock fittings for 1/8" cable, using either a PL-KEY or 1/4" diameter bolt, insert the PL-KEY or bolt into the hole and press until the wedges move freely. Perform the same operation for a 3/16" Pull-Lock or Push-Lock, except use a 16d nail or another tool with 1/8" or smaller diameter. Anything larger than what is recommended can actually get stuck inside the fitting — NOT what you want!

- Hold the cable with one hand and slide the Pull-Lock fitting into the hole in the post. Press on the back of the Pull-Lock fitting to hold it securely in the post and pull the cable through the fitting until it is as tight as you can make it.

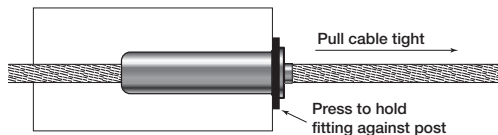

- Cut the cable flush with the hole in the back of the Pull-Lock fitting, using a cut-off wheel (see CUT-OFF KIT in our product catalog).

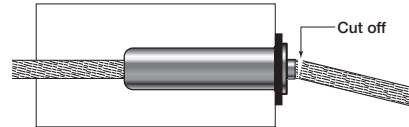

- Press the cap onto the lip of the Pull-Lock fitting.

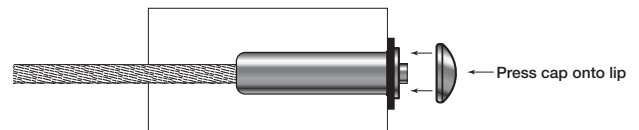

- Tension the cable with the tensioner installed on the end post (Post A) at the other end of the cable run, after all the fittings have been installed in both end posts. Tension all cables in sequence, beginning with the center cables, moving up and down toward the top and bottom. As you tension each cable, give it a sharp pull downward mid-span to help set the wedges, then re-tension as necessary in the same sequence.

